

PART NUMBER		LDS-A404RE	REV	A
REV	E.C.N. NUMBER AND REVISION COMMENTS			DATE
A	ECN-Lumex201700025			06.09.17

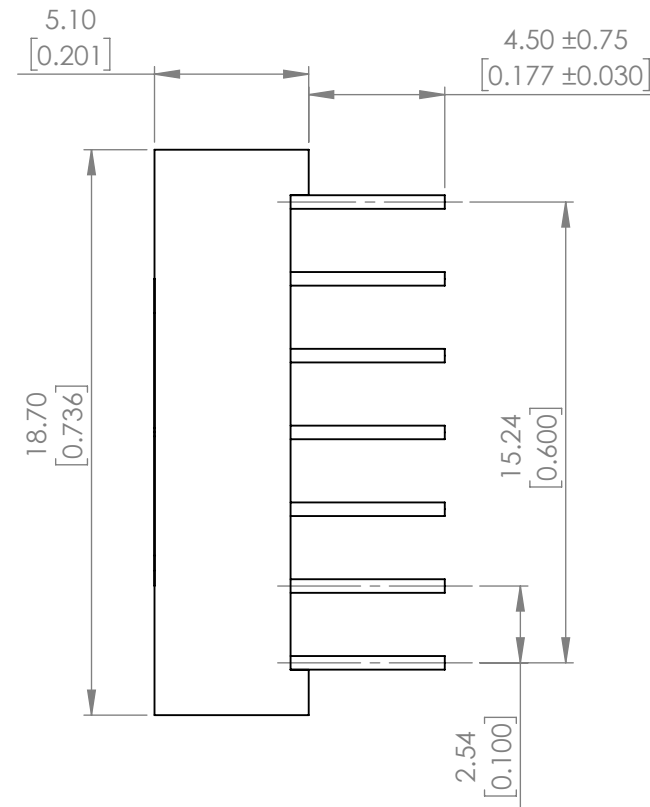
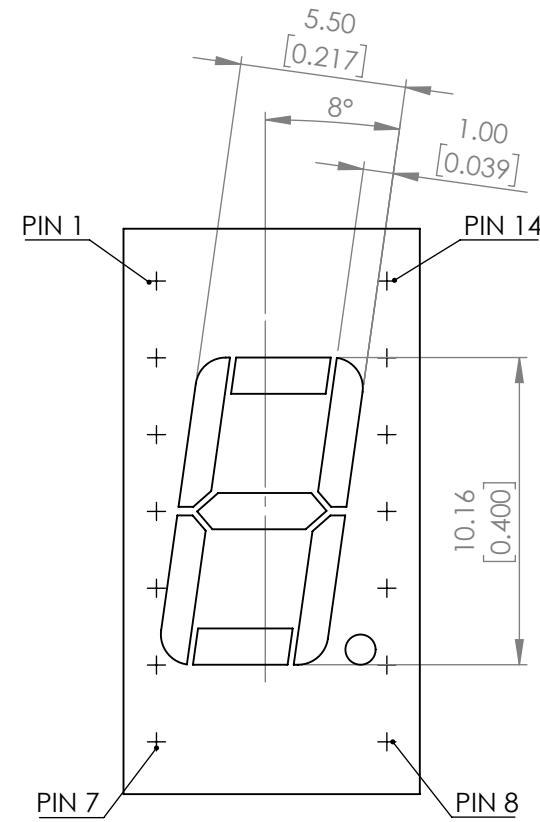

ELECTRO-OPTICAL CHARACTERISTIC TA=25°C PER SEGMENT

PARAMETER	MIN	TYP	MAX	UNITS	TEST COND
PEAK WAVELENGTH	-	635	-	nm	If=20mA
FORWARD VOLTAGE	-	2.0	2.5	Vf	If=20mA
REVERSE VOLTAGE	-	-	5	Vr	Ir=100uA
LUMINOUS INTENSITY	-	5600	-	ucd	If=10mA
EMITTED COLOR	RED				
FONT COLOR	BLACK				
SEGMENT COLOR	RED				

ABSOLUTE MAXIMUM RATINGS TA=25°C PER SEGMENT

PARAMETER	MAX	UNITS
PEAK FORWARD CURRENT*	100	mA
FORWARD CURRENT	25	mA
POWER DISIPATION	62.5	mW
STORAGE TEMPERATURE	-35 TO +85	°C
OPERATING TEMPERATURE	-35 TO +85	°C
SOLDERING TEMPERATURE**	3 SEC MAX. @ 260	°C

* t<10us

** AT 2mm DISTANCE FROM THE CASE OF REFLECTOR EDGE.

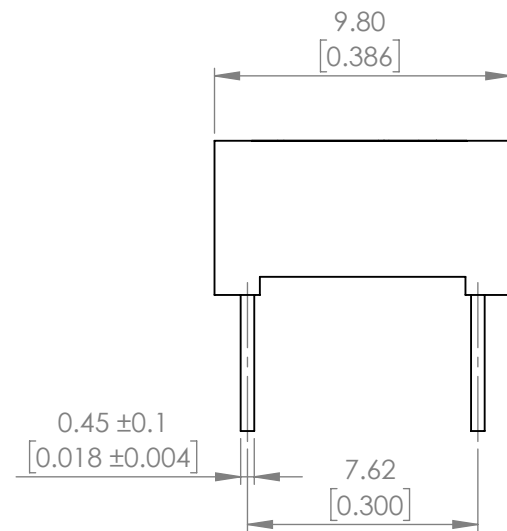

POLARITY

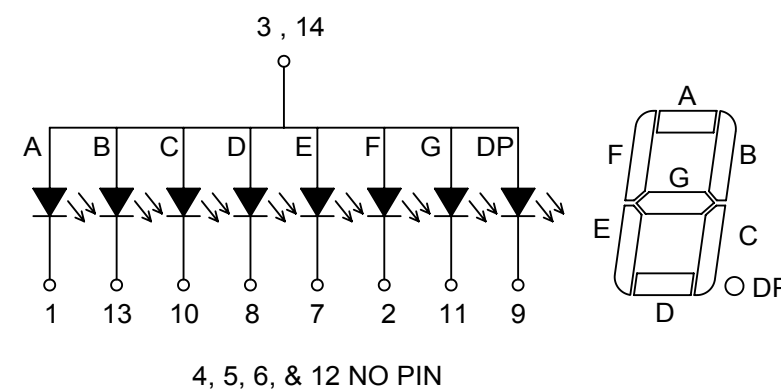

*UNLESS OTHERWISE SPECIFIED TOLERANCES PER DECIMAL PRECISION ARE: X=±1 (±0.039), X.X=±0.5 (±0.020), X.XX=±0.25 (±0.010), X.XXX=±0.127 (±0.005). LEAD SIZE=±0.05 (±0.002), LEAD LENGTH=±0.75 (±0.030). MIN= ^{+DECIMAL PRECISION}/_{-0.00} MAX.= ^{+0.00}/_{-DECIMAL PRECISION}

 <p>425 N. GARY AVE. CAROL STREAM, IL 60188 PHONE : 800-278-5666 FAX : 630-315-2150 WEB : WWW.LUMEX.COM</p>	18.70(L)*9.80(W)*5.10(H)mm, 0.4" SINGLE DIGIT SEVEN SEGMENT DISPLAY, 635nm RED, BLACK FACE WITH RED SEGMENTS, COMMON ANODE.	DATE : 2017.06.09	DRAWN BY : C.C.	
	THE SPECIFICATIONS MAY CHANGE AT ANY TIME WITHOUT NOTICE DUE TO NEW MATERIALS OR PRODUCT IMPROVEMENT.	PAGE : 1 OF 1	CHKD BY : G.Y.	
	CONFIDENTIAL INFORMATION THE INFORMATION CONTAINED IN THIS DOCUMENT IS THE PROPERTY OF LUMEX INC. EXCEPT AS SPECIFICALLY AUTHORIZED IN WRITING BY LUMEX INC., THE HOLDER OF THIS DOCUMENT SHALL KEEP ALL INFORMATION CONTAINED HEREIN CONFIDENTIAL AND SHALL PROTECT SAME IN WHOLE OR IN PART FROM DISCLOSURE AND DISSEMINATION TO ALL THIRD PARTIES.	SCALE : NTF	APRVD BY : R.C.	
		UNIT : mm [INCH]		