

UNCONTROLLED DOCUMENT

PART NUMBER  
OCP-PCT114/X-TR

REV.  
E

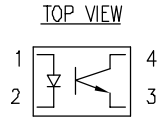
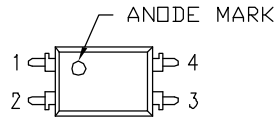

- NOTES:
1. ANODE
  2. CATHODE
  3. EMITTER
  4. COLLECTOR

REV.	E.C.N. NUMBER AND REVISION COMMENTS	DATE
A	E.C.N. #10BRDR. & #10776.	8.16.01
B	E.C.N. #10815.	12.3.01
C	E.C.N. #10894.	7.26.02
D	E.C.N. #11148.	5.16.07
E	E.C.N. #11148.	5.16.07

RECOMMENDED SOLDER PAD LAYOUT

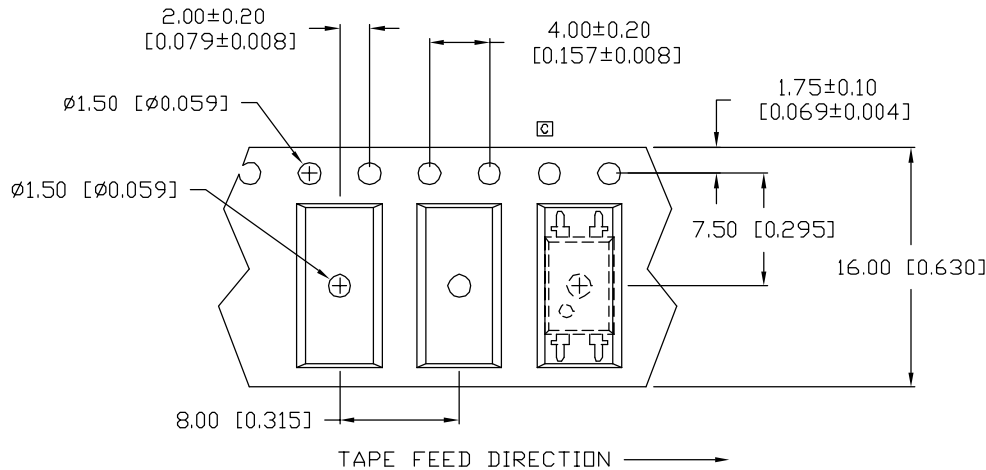
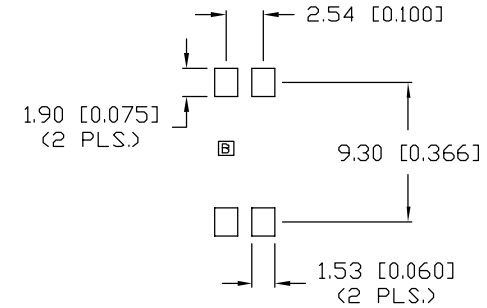
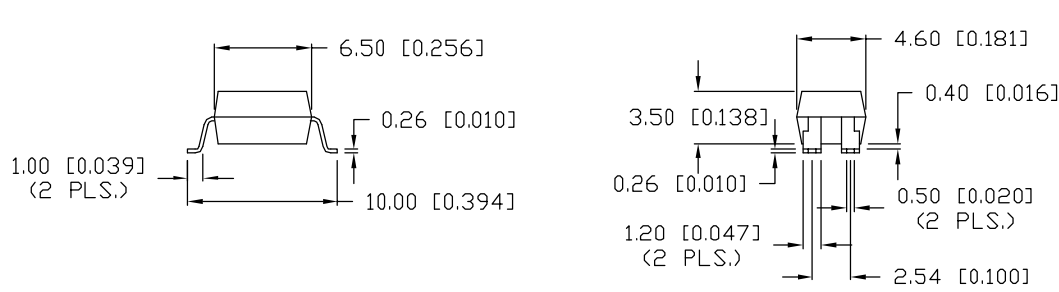

PART NUMBER TABLE	
PART= /X	CTR (%)
/A	60 TO 160
/B	130 TO 260
/C	200 TO 400
/D	300 TO 600
/E	50 TO 600



\*UNLESS OTHERWISE SPECIFIED TOLERANCES PER DECIMAL PRECISION ARE: X=±1 (±0.039), X.X=±0.5 (±0.020), X.XX=±0.25 (±0.010), X.XXX=±0.127 (±0.005). LEAD SIZE=±0.05 (±0.002), LEAD LENGTH=±0.75 (±0.030). MIN.= +DECIMAL PRECISION MAX.= +0.00 -DECIMAL PRECISION

UNCONTROLLED DOCUMENT

REV. E PART NUMBER OCP-PCT114/X-TR  
FOUR PIN SURFACE MOUNT SINGLE CHANNEL PHOTOCOUPLER,  
TRANSISTOR OUTPUT WITHOUT EXTERNAL BASE CONNECTION.

CONFIDENTIAL INFORMATION  
THE INFORMATION CONTAINED IN THIS DOCUMENT IS THE PROPERTY OF LUMEX INC. EXCEPT AS SPECIFICALLY AUTHORIZED IN WRITING BY LUMEX INC., THE HOLDER OF THIS DOCUMENT SHALL KEEP ALL INFORMATION CONTAINED HEREIN CONFIDENTIAL AND SHALL PROTECT SAME IN WHOLE OR IN PART FROM DISCLOSURE AND DISSEMINATION TO ALL THIRD PARTIES.  
RELIABILITY NOTE  
OUR MANY YEARS OF EXPERIENCE DATA ACCUMULATION INDICATE THAT SOLDER HEAT IS A MAJOR CAUSE OF EARLY AND FUTURE FAILURE. PLEASE PAY ATTENTION TO YOUR SOLDERING PROCESS.

**LUMEX**  
We have solutions to work for you  
INC.

DRAWN BY: JC

290 E. HELEN ROAD  
PALATINE, IL 60067-6976  
PHONE: +1.847.359.2790  
US WEB: www.lumex.com  
TW WEB: www.lumex.com.tw

CHECKED BY: APPROVED BY: DATE: 9.29.99  
PAGE: 1 OF 2  
SCALE: N/A

UNCONTROLLED DOCUMENT

PART NUMBER		REV.
OCP-PCT114/X-TR		E
REV.	E.C.N. NUMBER AND REVISION COMMENTS	DATE
	SEE PAGE 1.	

ELECTRO-OPTICAL CHARACTERISTICS (Ta=25°C)

PARAMETER	SYMBOL	CONDITIONS	MIN	TYP	MAX	UNITS
I FORWARD VOLTAGE	V <sub>F</sub>	I <sub>F</sub> =20mA	-	1.2	1.4	V
PEAK FORWARD VOLTAGE	V <sub>FM</sub>	I <sub>FM</sub> =0.5A	-	-	3.5	V
REVERSE CURRENT	I <sub>R</sub>	V <sub>R</sub> =4V	-	-	10	μA
TERMINAL CAPACITANCE	C <sub>t</sub>	V=0, f=1kHz	-	30	-	pF
O COLLECTOR DARK CURRENT	I <sub>CEO</sub>	V <sub>CE</sub> =20V	-	-	10 <sup>-7</sup>	A
T CURRENT TRANSFER RATIO	CRT	I <sub>F</sub> =2mA, V <sub>CE</sub> =5V	50	-	600	%
COLLECTOR-EMITTER SATURATION VOLTAGE	V <sub>CE(sat)</sub>	I <sub>F</sub> =20mA, I <sub>C</sub> =1mA	-	0.1	0.3	V
ISOLATION RESISTANCE	R <sub>ISO</sub>	DC500V	5x10 <sup>10</sup>	10 <sup>11</sup>	-	ohm
FLOATING CAPACITANCE	C <sub>f</sub>	V=0, f=1MHz	-	0.6	1.0	pF
CUT-OFF FREQUENCY	f <sub>c</sub>	V <sub>CE</sub> =5V, I <sub>C</sub> =2mA, R <sub>L</sub> =100ohm	-	80	-	kHz
RESPONSE TIME (RISE)	t <sub>r</sub>	V <sub>CE</sub> =5V, I <sub>C</sub> =2mA, R <sub>L</sub> =100ohm	-	5	20	μS
RESPONSE TIME (FALL)	t <sub>f</sub>	V <sub>CE</sub> =5V, I <sub>C</sub> =2mA, R <sub>L</sub> =100ohm	-	4	20	μS

I=INPUT, O=OUTPUT, T=TRANSFER CHARACTERISTICS.

ABSOLUTE MAXIMUM RATINGS (Ta=25°C)

PARAMETER	SYMBOL	MAX	UNITS
I FORWARD CURRENT	I <sub>F</sub>	50	mA
PEAK FORWARD CURRENT	I <sub>FM</sub>	1	A
REVERSE VOLTAGE	V <sub>R</sub>	6	V
POWER DISSIPATION	P <sub>D</sub>	70	mW
O COLLECTOR-EMITTER VOLTAGE	V <sub>CEO</sub>	60	V
EMITTER-COLLECTOR VOLTAGE	V <sub>ECO</sub>	6	V
COLLECTOR CURRENT	I <sub>C</sub>	50	mA
COLLECTOR POWER DISSIPATION	P <sub>C</sub>	150	mW
TOTAL POWER DISSIPATION	P <sub>TOT</sub>	200	mW
ISOLATION VOLTAGE 1 MIN.	V <sub>ISO</sub>	5000	V <sub>RMS</sub>
OPERATING TEMPERATURE	T <sub>opr</sub>	- 30 TO + 100	°C
STORAGE TEMPERATURE	T <sub>stg</sub>	- 55 TO + 125	°C
SOLDERING TEMPERATURE	T <sub>sol</sub>	+ 260	°C
2.0mm FROM BODY			10 SEC. MAX

I=INPUT, O=OUTPUT.

\*UNLESS OTHERWISE SPECIFIED TOLERANCES PER DECIMAL PRECISION ARE: X=±1 (±0.039), X.X=±0.5 (±0.020), X.XX=±0.25 (±0.010), X.XXX=±0.127 (±0.005). LEAD SIZE=±0.05 (±0.002), LEAD LENGTH=±0.75 (±0.030). MIN.=+DECIMAL PRECISION MAX.=+0.00 -0.00 -DECIMAL PRECISION

UNCONTROLLED DOCUMENT

REV. E	PART NUMBER OCP-PCT114/X-TR	<p>CONFIDENTIAL INFORMATION</p> <p>THE INFORMATION CONTAINED IN THIS DOCUMENT IS THE PROPERTY OF LUMEX INC. EXCEPT AS SPECIFICALLY AUTHORIZED IN WRITING BY LUMEX INC., THE HOLDER OF THIS DOCUMENT SHALL KEEP ALL INFORMATION CONTAINED HEREIN CONFIDENTIAL AND SHALL PROTECT SAME IN WHOLE OR IN PART FROM DISCLOSURE AND DISSEMINATION TO ALL THIRD PARTIES.</p> <p>RELIABILITY NOTE</p> <p>OUR MANY YEARS OF EXPERIENCE DATA ACCUMULATION INDICATE THAT SOLDER HEAT IS A MAJOR CAUSE OF EARLY AND FUTURE FAILURE. PLEASE PAY ATTENTION TO YOUR SOLDERING PROCESS.</p>	 <p>290 E. HELEN ROAD PALATINE, IL 60067-6976 PHONE: +1.847.359.2790 US WEB: www.lumex.com TW WEB: www.lumex.com.tw</p>
FOUR PIN SURFACE MOUNT SINGLE CHANNEL PHOTOCOUPLER, TRANSISTOR OUTPUT WITHOUT EXTERNAL BASE CONNECTION.		<p>DRAWN BY: JC</p> <p>CHECKED BY:</p> <p>APPROVED BY:</p>	<p>DATE: 9.29.99</p> <p>PAGE: 2 OF 2</p> <p>SCALE: N/A</p>