

<b>PART NUMBER</b>		SML-LX0404SIUPGUSB	<b>REV</b>	C
<b>REV</b>	<b>E.C.N. NUMBER AND REVISION COMMENTS</b>		<b>DATE</b>	
A	E.C.N. #11941		05.11.15	
B	E.C.N. #11956		06.03.15	
C	ECN-Lumex201700046		05.11.15	

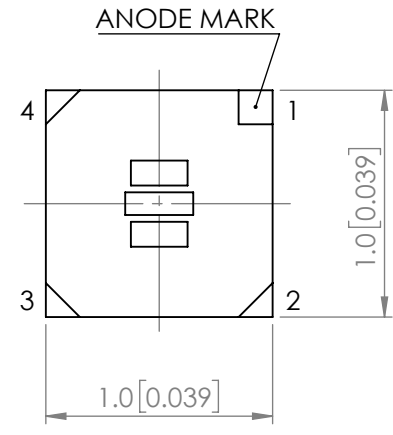

**POLARITY**

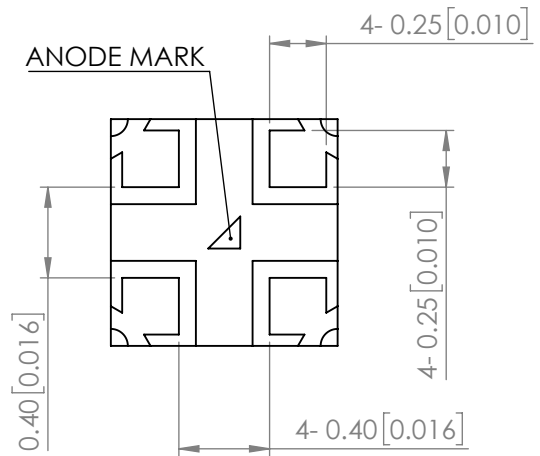
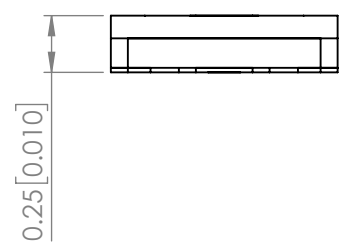
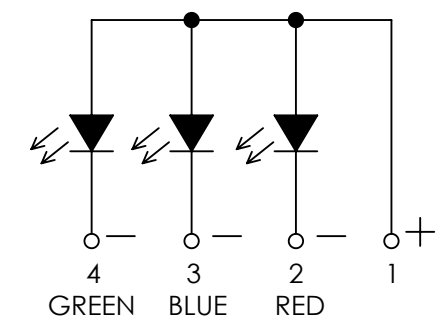

**RECOMMENDED SOLDER PAD LAYOUT**

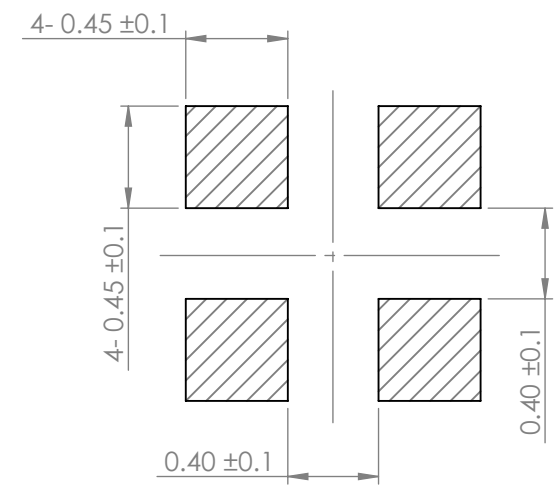

**ELECTRO-OPTICAL CHARACTERISTIC TA=25°C**

PARAMETER	MIN	TYP	MAX	UNITS	TEST COND	
PEAK WAVELENGTH	R	-	632	-	nm	If=2mA
	G	-	518	-		
	B	-	468	-		
FORWARD VOLTAGE	R	-	1.95	2.15	Vf	If=2mA
	G	-	2.75	2.95		
	B	-	2.70	2.85		
REVERSE VOLTAGE	R	-	-	5	Vr	Ir=10uA
	G	-	-	5		Ir=50uA
	B	-	-	5		Ir=50uA
LUMINOUS INTENSITY	R	-	35	-	mcd	If=2mA
	G	-	50	-		
	B	-	20	-		
VIEWING ANGLE	-	120	-	2x theta1/2	-	-
EMITTED COLOR	RED / GREEN / BLUE					
EPOXY LENS FINISH	WATER CLEAR					

**ABSOLUTE MAXIMUM RATINGS TA=25°C**

PARAMETER	MAX	UNITS
PEAK FORWARD CURRENT(R/G/B)*	60 / 100 / 20	mA
FORWARD CURRENT(R/G/B)	25 / 25 / 10	mA
POWER DISIPATION(R/G/B)	60 / 95 / 30	mW
STORAGE TEMPERATURE	-40 TO +90	°C
OPERATING TEMPERATURE	-40 TO +85	°C

\*t<10us

**NOTE:**  
1. RoHS COMPLIANT.

MOISTURE SENSITIVE DEVICE  
PER JEDEC LEVEL 2a STANDARDS

\*UNLESS OTHERWISE SPECIFIED TOLERANCES PER DECIMAL PRECISION ARE: X=±1 (±0.039), X.X=±0.5 (±0.020), X.XX=±0.25 (±0.010), X.XXX=±0.127 (±0.005). LEAD SIZE=±0.05 (±0.002), LEAD LENGTH=±0.75 (±0.030). MIN= <sup>+DECIMAL PRECISION</sup> / <sub>-0.00</sub> MAX= <sup>+0.00</sup> / <sub>-DECIMAL PRECISION</sub>

**PROFILE**

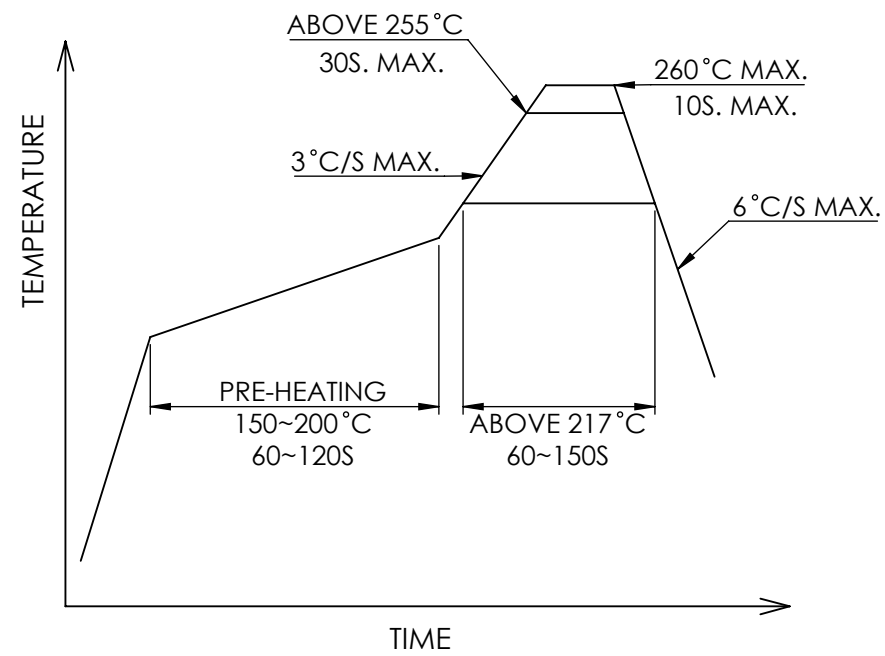

**CARRIER TAPE DIMENSION**

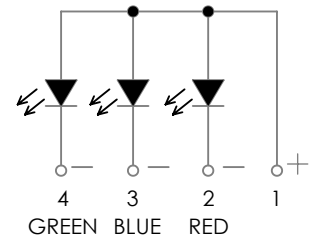
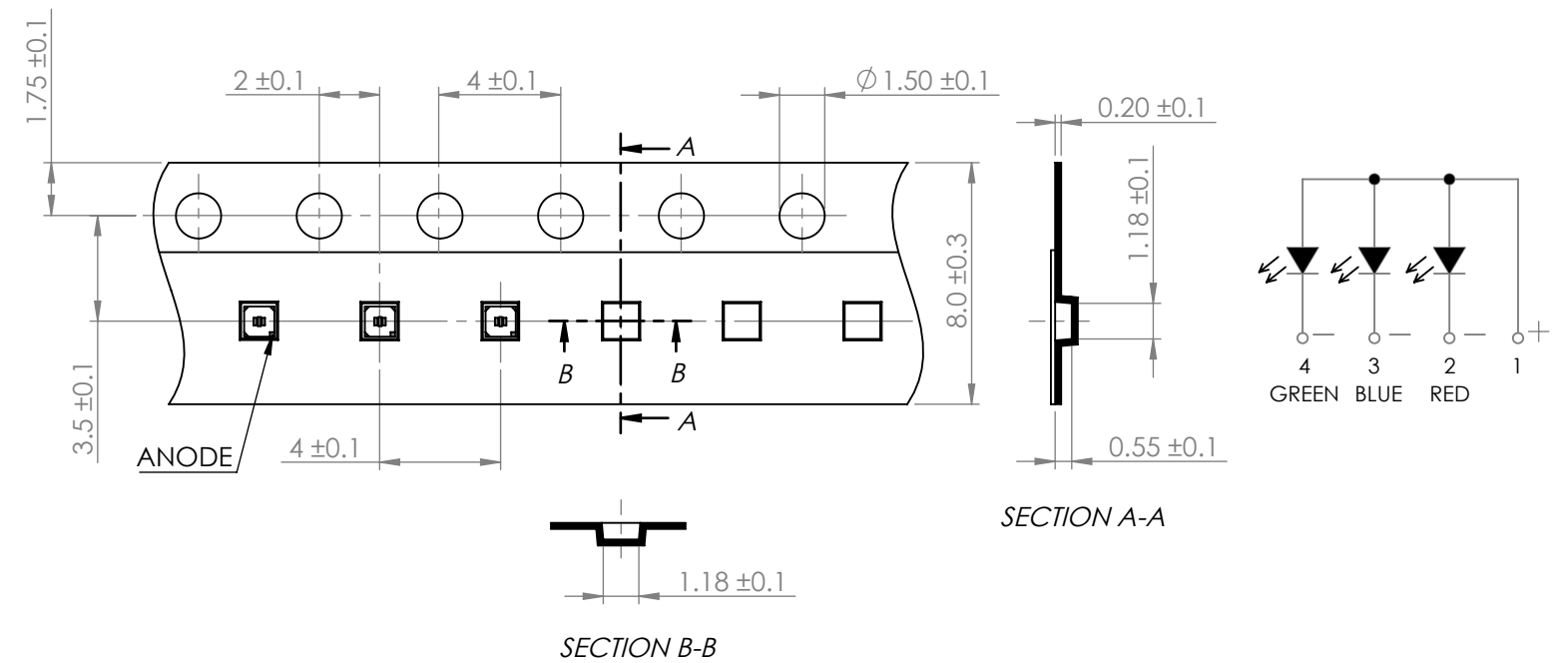

\*UNLESS OTHERWISE SPECIFIED TOLERANCES PER DECIMAL PRECISION ARE: X=±1 (±0.039), X.X=±0.5 (±0.020), X.XX=±0.25 (±0.010), X.XXX=±0.127 (±0.005). LEAD SIZE=±0.05 (±0.002), LEAD LENGTH=±0.75 (±0.030). MIN= <sup>+DECIMAL PRECISION</sup> / <sub>-0.00</sub> MAX.= <sup>+0.00</sup> / <sub>-DECIMAL PRECISION</sub>

 <p>425 N. GARY AVE. CAROL STREAM, IL 60188 PHONE : 800-278-5666 FAX : 630-315-2150 WEB : WWW.LUMEX.COM</p>	1(L)*1(W)*0.25(H)mm, SURFACE MOUNT TOP VIEW LED, AlGaInP RED / InGaN GREEN / InGaN BLUE, WATER CLEAR LENS, TAPE & REEL	DATE : 2017.08.10	DRAWN BY : C.C.	
	**THE SPECIFICATIONS MAY CHANGE AT ANY TIME WITHOUT NOTICE DUE TO NEW MATERIALS OR PRODUCT IMPROVEMENT.**	PAGE : 2 OF 2	CHKD BY : G.Y.	
	CONFIDENTIAL INFORMATION	SCALE : NTF	APRVD BY : E.C.	
	THE INFORMATION CONTAINED IN THIS DOCUMENT IS THE PROPERTY OF LUMEX INC. EXCEPT AS SPECIFICALLY AUTHORIZED IN WRITING BY LUMEX INC., THE HOLDER OF THIS DOCUMENT SHALL KEEP ALL INFORMATION CONTAINED HEREIN CONFIDENTIAL AND SHALL PROTECT SAME IN WHOLE OR IN PART FROM DISCLOSURE AND DISSEMINATION TO ALL THIRD PARTIES.	UNIT : mm [INCH]	